



INDUSTRIES(Pty)Ltd

Tel : +27 (0) 11 237 6900
Fax : +27 (0) 11 316 4224

32 Main Road / PO Box 1200
Clayville Ext 4
Olifantsfontein, 1665, RSA



TFM ECONOMASTER



ECONOMASTER



Major Features Include:

- ◆ User Friendly
- ◆ Extremely Cost Effective
- ◆ Suitable for Informal Settlements

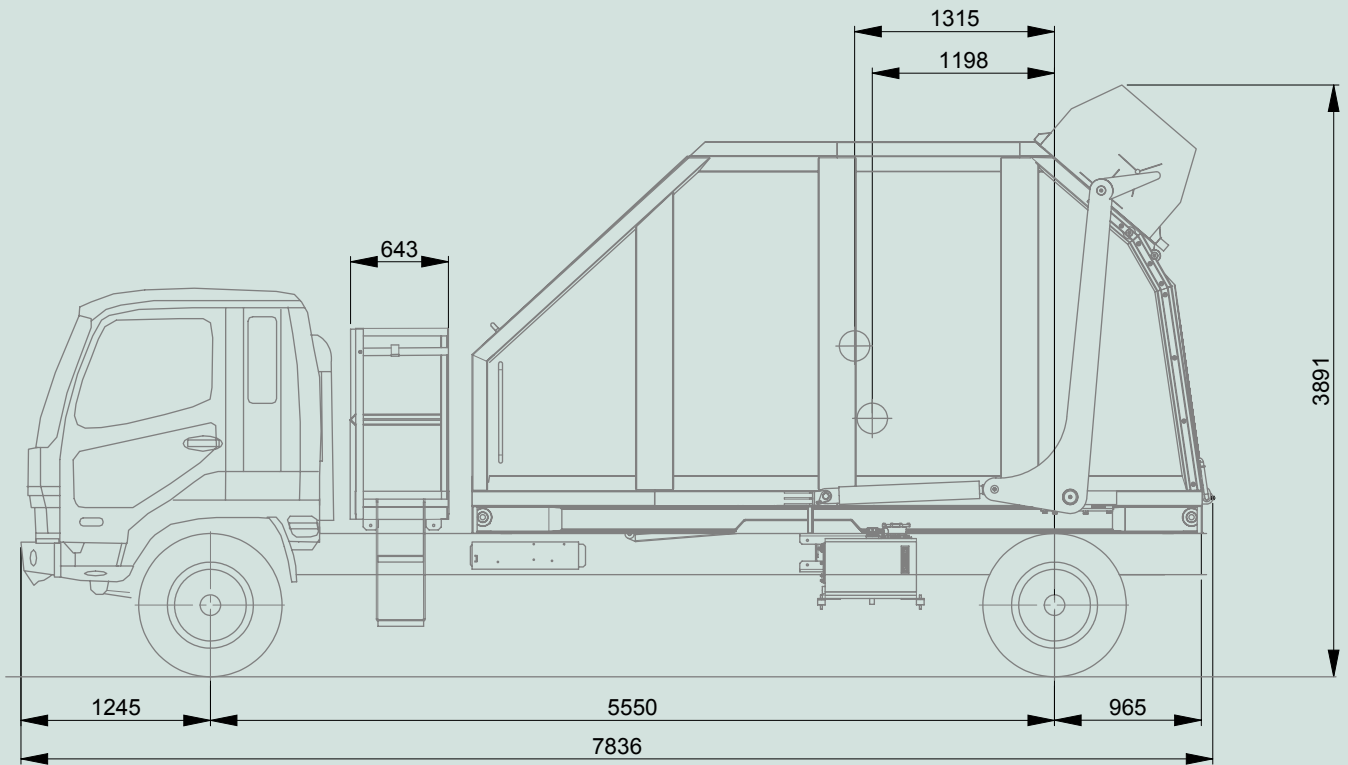

DIMENSIONS

- | | |
|---|----------|
| ▪ Height (Approximate)
With Hopper in Transit Position | 3 695 mm |
| ▪ Width (Total) | 2 600 mm |
| ▪ Body Length | 4 800 mm |
| ▪ Load Length | 750 mm |

CAPACITIES

- | | |
|----------|-------------------|
| ▪ Body | 20m ³ |
| ▪ Hopper | 1.3m ³ |

MASSES

- | | |
|-------------|-----------------------|
| ▪ Payload | 5 000 kg ⁺ |
| ▪ Body Tare | 2 434 kg |

HYDRAULICS

- | | |
|----------------------------|---|
| ▪ Pump - PTO driven - Gear | 90 l/m @ 1 300 RPM |
| ▪ System Pressure | 14 MPa |
| ▪ Oil Reservoir | 112 l |
| ▪ Cylinder Bore | <ul style="list-style-type: none"> ◦ Hopper : 80mm ◦ Stabilizer : 80mm |
| ▪ Filter | <ul style="list-style-type: none"> ◦ Suction : 25 micron ◦ Return : 10 micron |
| ▪ Cycle Times | <ul style="list-style-type: none"> ◦ Hopper : 12sec ◦ Compaction : 12 sec ◦ Tip : 14 sec |

